

MT (Multi-Turn)

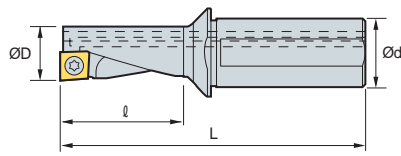
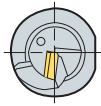

(mm)

Designation		ØD	Ød	l	L	Insert	Screw	Wrench
MT	10R/L-2.25D	10	12	22.5	69.5	QC□T050204	FTNA0204S	TW06P
	12R/L-2.25D	12	16	27.0	78.0	QC□T060204	FTNA02205S	TW06P
	14R/L-2.25D	14	16	31.5	83.5	QC□T070304	FTKA02555	TW07P
	16R/L-2.25D	16	20	36.0	94.0	QC□T080304	FTNA0306	TW09P
	20R/L-2.25D	20	25	45.0	111.0	QC□T10T304	FTNA03508	TW15P
	25R/L-2.25D	25	32	56.5	130.0	QC□T130408	FTNC04509	TW20S
	32R/L-2.25D	32	40	72.0	160.0	QC□T170508	FTNC04511	TW20S

Insert

Picture	Designation	Coated				Uncoated		Dimensions (mm)					Configuration
		NC3120	NC3225	NC6315	PC5300	H01	H05	l	d	t	r	Ød ₁	
	QCMT 050204-CM		●	●	●			5.0	5.4	2.10	0.4	2.3	
	060204-CM		●	●	●			6.0	6.4	2.38	0.4	2.5	
	070304-CM		●	●	●			7.0	7.4	3.18	0.4	2.8	
	080304-CM		●	●	●			8.0	8.4	3.18	0.4	3.4	
	10T304-CM		●		●			10.0	10.4	3.97	0.4	4.0	
	130408-CM		●		●			12.7	13.5	4.76	0.8	5.5	
	170508-CM		●	●	●			16.7	17.5	5.56	0.8	5.5	
	QCGT 050204-CA					●		5.0	5.4	2.10	0.4	2.3	
	060204-CA					●		6.0	6.4	2.38	0.4	2.5	
	070304-CA					●		7.0	7.4	3.18	0.4	2.8	
	080304-CA					●		8.0	8.4	3.18	0.4	3.4	
	10T304-CA					●		10.0	10.4	3.97	0.4	4.0	
	130408-CA					●		12.7	13.5	4.76	0.8	5.5	
	170508-CA					●		16.7	17.5	5.56	0.8	5.5	



Bearing Solution

Code system

• Insert

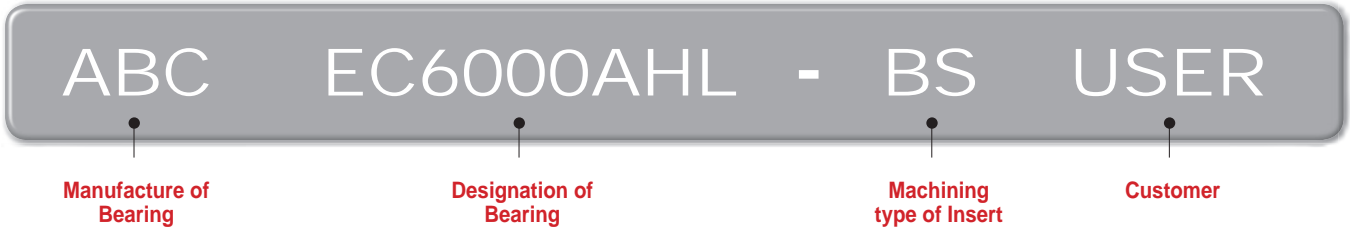

• Holder

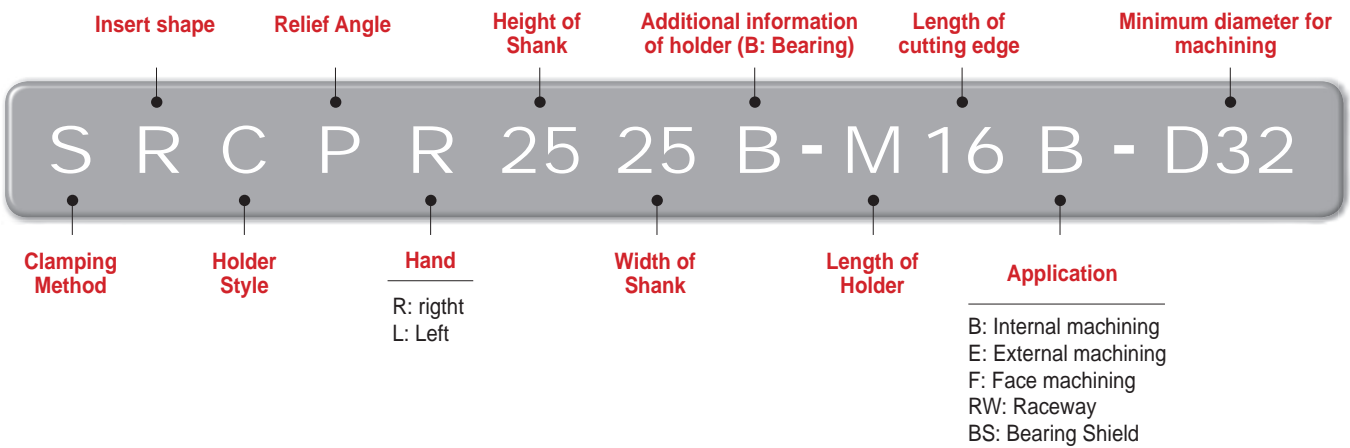

B Bearing Solution

CMSN...F Type

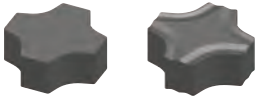

MC12□□ MC12□□-BR
MC15□□

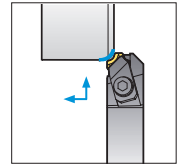
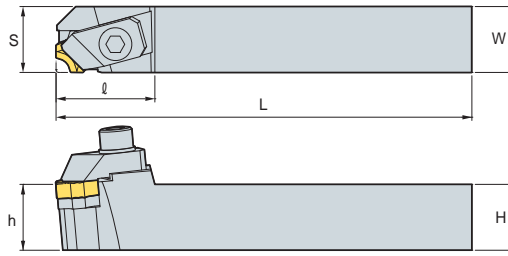
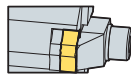

• R type insert (mm)

Designation	H	W	L	S	h	q	Insert	Clamp	Clamp Screw	Shim	Shim Screw	Wrench
CMSNR/L 2020B-L12F	20	20	140	21	20	33	MC12□□	CH6R/L1B	BHA0620	SX42CB	SS0308	HW50L
2023B-L12F	20	23	140	24	20	33	MC12□□-BR					
2525B-L15F	25	25	140	26	25	35	MC15□□	CH6R/L1B	BHA0620	SX52CB	SS0408	HW50L

CMSN...B Type

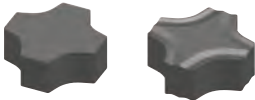

MC12□□ MC12□□-BR

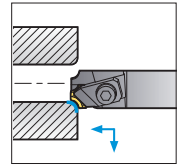
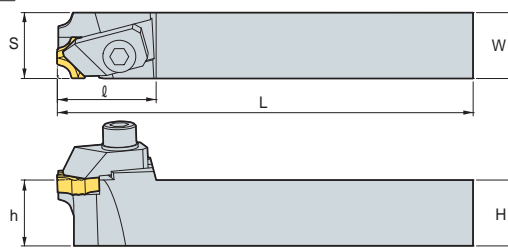
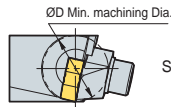

• R type insert (mm)

Designation	ØD	H	W	L	S	h	q	Insert	Clamp	Clamp Screw	Shim	Shim Screw	Wrench
CMSNR/L 2020B-L12B-D28	28	20	20	140	21	20	33	MC12□□	CH6R/L1B	BHA0620	SX42CB	SS0308	HW50L
2525B-L12B-D28	28	25	25	140	26	25	33		CH6R/L1B	BHA0620	SX42CB	SS0308	HW50L
1620B-L12B-D20	20	16	20	140	18	16	32	MC12□□-BR	CH6R/L1B	BHA0620	-	-	HW50L
2023B-L12B-D28	28	20	23	140	24	20	33		CH6R/L1B	BHA0620	SX42CB	SS0308	HW50L

Insert

Application	Picture	Designation	Cermet	Dimensions (mm)					Configuration
			CN2500	R	θ°	B	d	t	
R-Chamfering		MC0906		0.6	12	1.8	9.525	3.18	
		MC0910		1.0	12	2.4	9.525	3.18	
		MC1206		0.6	18	1.8	12.7	4.76	
		MC1210		1.0	18	2.4	12.7	4.76	
		MC1212		1.2	18	2.2	12.7	4.76	
		MC1215		1.5	18	3.0	12.7	4.76	
		MC1220		2.0	18	3.8	12.7	4.76	
		MC1225		2.5	18	2.8	12.7	4.76	
		MC1525		2.5	18	4.0	15.875	5.56	
		MC1530		3.0	18	4.7	15.875	5.56	
	MC1540		4.0	20	4.7	15.875	5.56		
		MC1206-BR		0.6	18	1.8	12.7	4.76	
		MC1210-BR		1.0	18	2.4	12.7	4.76	
		MC1212-BR		1.2	18	2.2	12.7	4.76	
		MC1215-BR		1.5	18	3.0	12.7	4.76	
		MC1220-BR		2.0	18	3.2	12.7	4.76	
MC1230-BR			3.0	18	3.7	12.7	4.76		
MC1235-BR		3.5	18	3.9	12.7	4.76			

• Stock item

Special order-form

Designation	CN2500	R	θ°	B	d	t	Configuration
MC...							



SRGP...E Type



RPGT1203M0
RPGT1604M0
RPGT2004M0

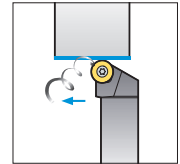
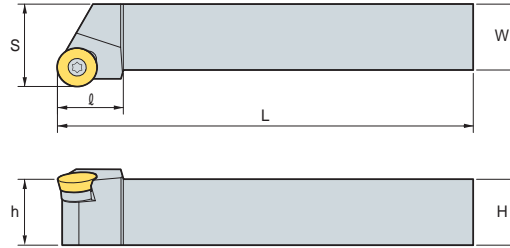

• R type insert
(mm)

Designation	H	W	L	S	h	l	Insert	Screw	Shim	Shim Screw	Wrench
SRGPR/L 2020B-L12E	20	20	140	25	20	20	RPGT1203M0	FTKA0410	SR1203S	SHXN0609F	TW15P
2020B-L16E	20	20	140	25	20	20	RPGT1604M0	FTNA0513	SR16T3S	SHXN0712F	TW20P
2525B-L20E	25	25	140	32	25	30	RPGT2004M0	FTNA0513	SR20T3S	SHXN0712F	TW20P

SRGP...F Type



RPGT1203M0
RPGT1604M0
RPGT2004M0

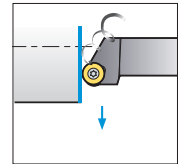
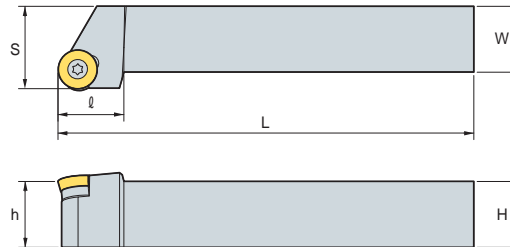

• R type insert
(mm)

Designation	H	W	L	S	h	l	Insert	Screw	Shim	Shim Screw	Wrench
SRGPR/L 2020B-L12F	20	20	140	25	20	20	RPGT1203M0	FTKA0410	SR1203S	SHXN0609F	TW15P
2020B-L16F	20	20	140	25	20	20	RPGT1604M0	FTNA0513	SR16T3S	SHXN0712F	TW20P
2525B-L20F	25	25	140	32	25	30	RPGT2004M0	FTNA0513	SR20T3S	SHXN0712F	TW20P

SRCP...B Type



RPGT0802M0
RPGT1203M0
RPGT1604M0

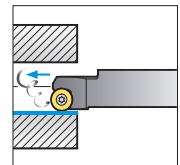
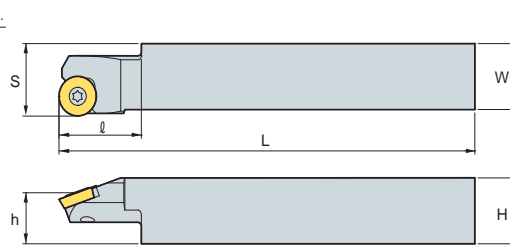
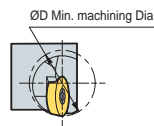

• R type insert
(mm)

Designation	ØD	H	W	L	S	h	l	Insert	Screw	Wrench
SRCPR/L 2020B-L08B-D12	12	20	20	140	21.5	15.5	25	RPGT0802M0	FTKA0305	TW09P
1919B-L12B-D15	15	19	19	140	21	16	25	RPGT1203M0	FTNA0408	TW15P
2020B-L12B-D20	20	20	20	140	22	15.5	25	RPGT1203M0	FTNA0408	TW15P
2525B-L16B-D32	32	25	25	140	27	20	30	RPGT1604M0	FTKA0510	TW20P

B Bearing Solution

CSKP...B Type



SPGR120440L

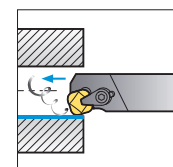
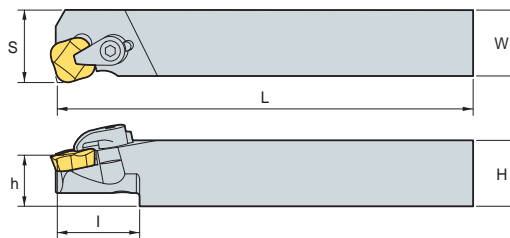
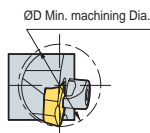

• R type insert (mm)

Designation	ØD	H	W	L	S	h	l	Insert	Clamp	Clamp Screw	Wrench
CSKPR/L 2022B-L12B-D30	30	20	22	140	27	20	37	SPGR120440R/L	CH5R1	CHX0510	HW30L

SSKP...B Type

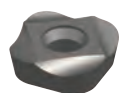

SPGH090330L

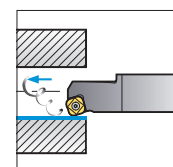
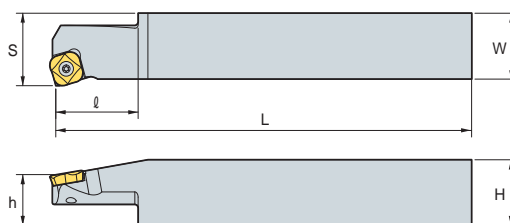
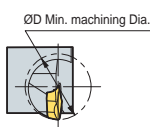

• R type insert (mm)

Designation	ØD	H	W	L	S	h	l	Insert	Screw	Wrench
SSKPR/L 2020B-L09B-D12	12	20	20	140	21.7	19	20	SPGH090330R/L	FTNA0307	TW09P
2020B-L09B-D13	13	20	20	140	21.7	19	20			
2020B-L09B-D20	20	20	20	140	21.7	19	20			

Insert

Application	Picture	Designation	Cermet	Dimensions (mm)				Configuration	
			CN2500	r	d	d ₁	t		
Internal turning		RPGT0802M0		-	8	3.4	2.38		
		RPGT1203M0		-	12	4.4	3.18		
		RPGT1604M0		-	16	5.5	4.76		
		RPGT2004M0		-	20	5.5	4.76		
		SPGR120440L			4.0	12.7	-	4.76	
		SPGH090330L			3.0	9.525	3.4	3.18	

• Stock item



CKFN...RW Type

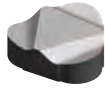

KORIC

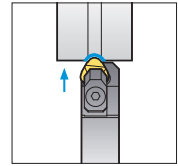
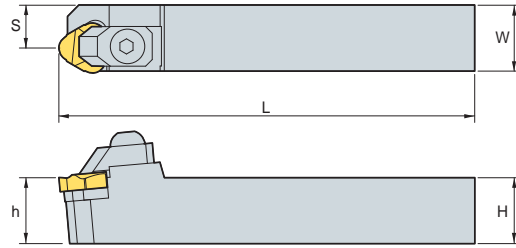
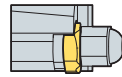

• R type insert (mm)

Designation	H	W	L	S	h	Insert	Clamp	Clamp Screw	Shim	Shim Screw	Wrench
CKFNR/L 2020B-L22RW	20	20	140	12.5	20	KORIC2204R/L	CH6N1B	BHA0620	ST42CB	SS0408	HW50L
2022B-L27RW	20	22	140	13	20	KORIC2704R/L	CH8R/L1B	BHA0820	ST52CB	SS0408	HW60L
2025B-L33RW	20	25	140	16	20	KORIC3306R/L	CH8R/L1B	BHA0820	ST62CB	SS0408	HW60L
2533B-L44RW	25	33	140	21	25	KORIC4408R/L	CH8R/L1B	BHA0820	ST82CB	SS0408	HW60L

CKGN...RW Type



KORIC

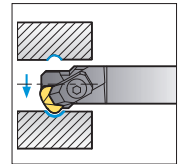
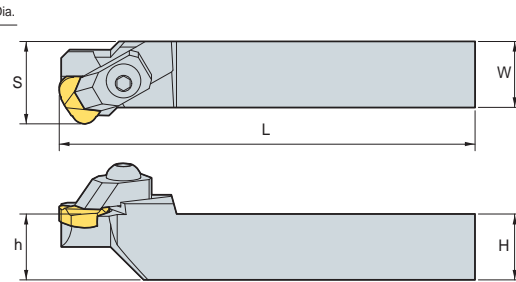
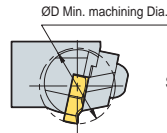

• R type insert (mm)

Designation	ØD	H	W	L	S	h	Insert	Clamp	Clamp Screw	Shim	Shim Screw	Wrench
CKGNR/L 2022B-L22RW-D23	23	20	22	140	30	20	KORIC2204R/L	CH6R/L3B	BHA0620	ST42CB	SS0408	HW50L
2022B-L27RW-D29	29	20	22	140	34	20	KORIC2704R/L	CH6R/L7B	BHA0620	ST52CB	SS0408	HW50L
2025B-L33RW-D38	38	20	25	140	33	20	KORIC3306R/L	CH6R/L5B	BHA0620	ST62CB	SS0408	HW50L
2528B-L38RW-D50	50	25	28	140	46	25	KORIC3806R/L	CH8R/L2B	BHA0820	ST72CB	SS0408	HW60L
2528B-L44RW-D52	52	25	28	140	50	25	KORIC4408R/L	CH8R/L2B	BHA0820	ST82CB	SS0408	HW60L

CSGN...RW Type

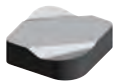

SNGN

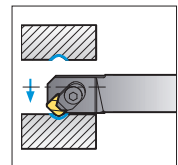
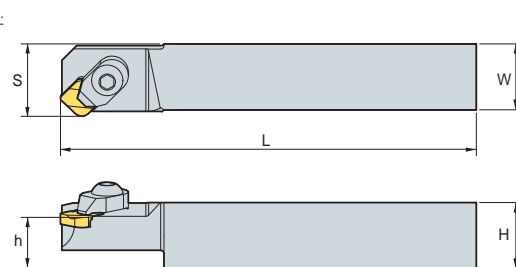
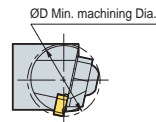

• R type insert (mm)

Designation	ØD	H	W	L	S	h	Insert	Clamp	Clamp Screw	Wrench
CSGNR/L 2020B-L09RW-D17	17	20	20	140	22	20	SNGN0903WR/L	CH5R1	CHX0510	HW30L
2020B-L09RW-D22	22	20	20	140	22	20	SNGN0903WR/L	CH5R1	CHX0510	HW30L



B Bearing Solution

CSBN...BS Type

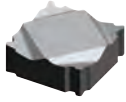

SNGN

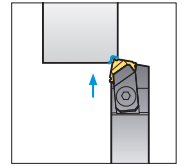
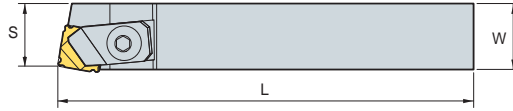
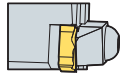

• R type insert (mm)

Designation	H	W	L	S	h	Insert	Clamp	Clamp Screw	Shim	Shim Screw	Wrench
CSBNR/L 2023B-L12BS	20	23	140	21	20	SNGN1204SR/L	CH6N1B	BHA0620	SS42CB	SS0308	HW50L
2525B-L15BS	25	25	140	23	25	SNGN1504SR/L	CH6N1B	BHA0620	SS52CB	SS0408	HW50L

CSKN...BS Type

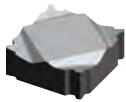

SNGN

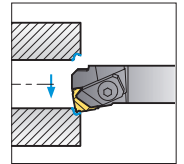
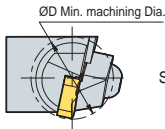

• R type insert (mm)

Designation	ØD	H	W	L	S	h	Insert	Clamp	Clamp Screw	Shim	Shim Screw	Wrench
CSKNR/L 1622B-L09BS-D14	14	16	22	140	16	16	SNGN0903SR/L	CH6R/L2B	BHA0620	-	-	HW50L
2022B-L12BS-D26	26	20	22	140	27	20	SNGN1204SR/L	CH6R/L1B	BHA0620	SS42CB	SS0308	HW50L
2525B-L15BS-D35	35	25	25	140	31	25	SNGN1504SR/L	CH6R/L3B	BHA0620	SS52CB	SS0408	HW50L

CTGN...BS Type



TNGN

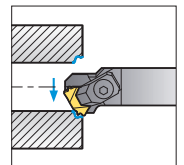
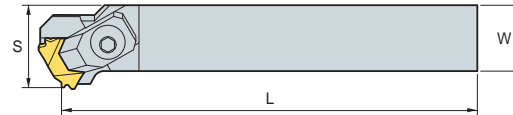
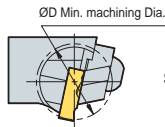

• R type insert (mm)

Designation	ØD	H	W	L	S	h	Insert	Clamp	Clamp Screw	Shim	Shim Screw	Wrench
CTGNR/L 2021B-K22BS-D25	25	20	21	140	30	20	TNGN2204SR/L	CH6R/L7B	BHA0620	ST42CB	SS0408	HW50L



Machining Race-way

KORIC... R/L Type

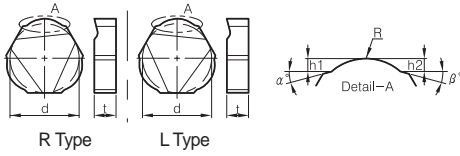

		d	t	R	h ₁	h ₂	α°	β°
KORIC	2204R/L	12.7	4.76					
	2704R/L	15.875	4.76					
	3306R/L	19.05	6.0					
	3806R/L	22.225	6.0					
	4408R/L	25.4	8.0					

SNGN... WR/L Type

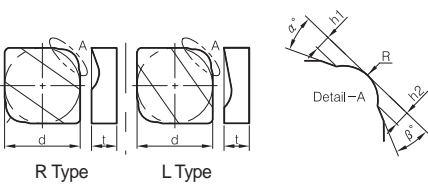

		d	t	R	h ₁	h ₂	α°	β°
SNGN	0903WR/L	9.525	3.18					
	1504WR/L	15.875	4.76					
	1905WR/L	19.05	5.56					

Machining for Bearing shield

KORIC... R/L Type

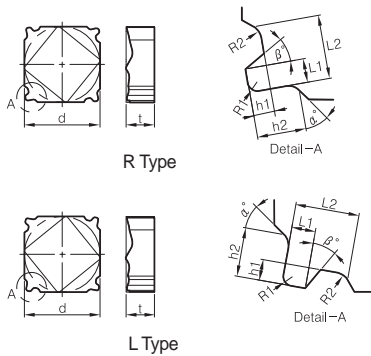

		d	t	L ₁	L ₂	h ₁	h ₂	R ₁	R ₂	α°	β°
SNGN	0903SR/L	9.525	3.18								
	1204SR/L	12.7	4.76								
	1504SR/L	15.875	4.76								

TNGN...SR/L Type

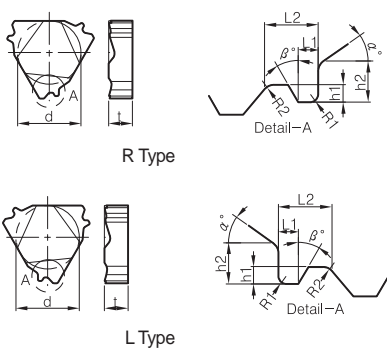

		d	t	L ₁	L ₂	h ₁	h ₂	R ₁	R ₂	α°	β°
TNGN	02204SR/L	12.7	4.76								