

KORLOY High Pressure Coolant

KHP Coolant **new**

ISO turning holder

- 300% increased productivity on Inconel machining vs. low pressure coolant system
- Cooling, tool life, and chip control are improved by the high volume coolant multi-directional injection system

Structure of Holder

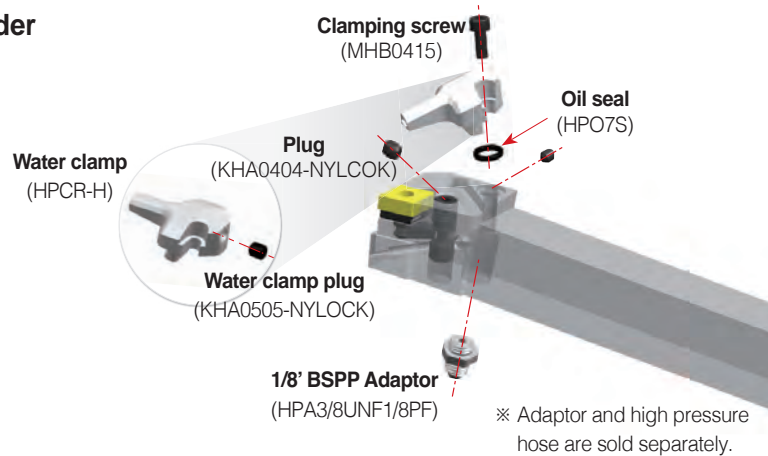

Features

- The optimal distance between the insert and the jet orifice and the ideal place of the jet orifice
- Maximized loss pressure of coolant pressure due to streamlined design of internal path
- Easy to clamp an insert for sliding clamp system

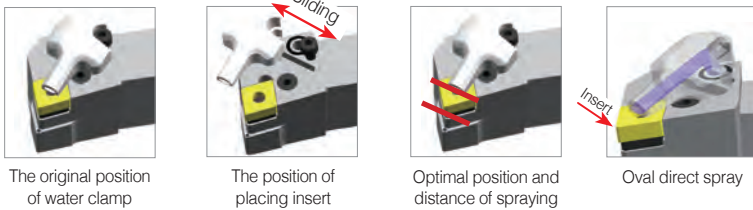

MAX 300 bar

Workpiece	The minimum pressure	The maximum pressure
P	50	300
M	70	
K	60	
N	50	
S	70	

Water clamp with a hole

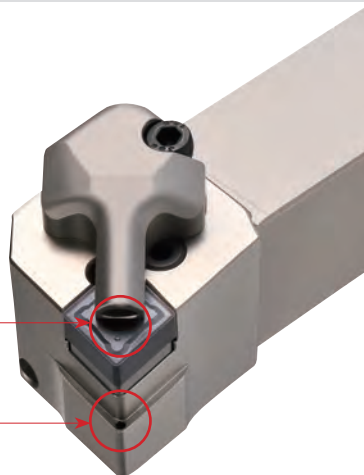

Spray to the upper surface of insert
 Spray to the bottom surface of insert

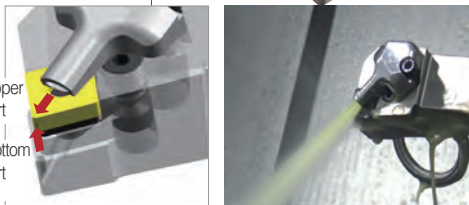

Water clamp with three holes

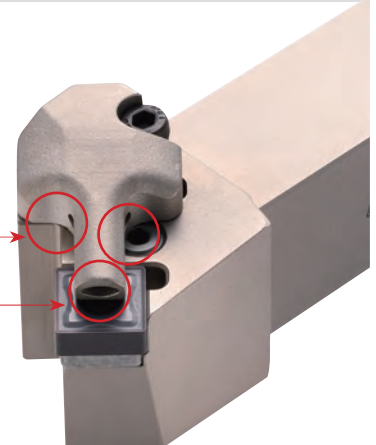

Injection through three holes on the rake surface

Injection on the bottom surface

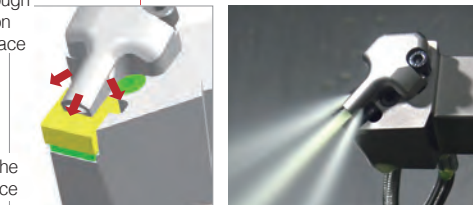

※ Clamp is sold separately

B Technical Information for KHP Coolant

How to use the water clamp



Application range

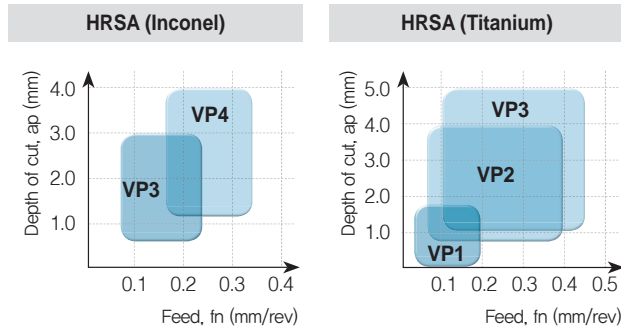

Grade Line-up

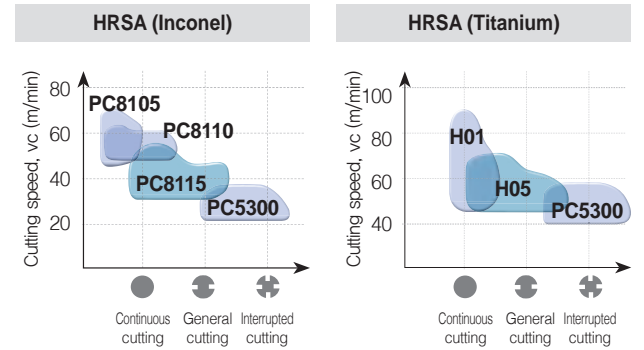

How to clamp the KHP Coolant

- 3 types of installation systems makes clamping easy
- The banjo type hose provides wider area for machining than other types

Straight to straight (S-S)

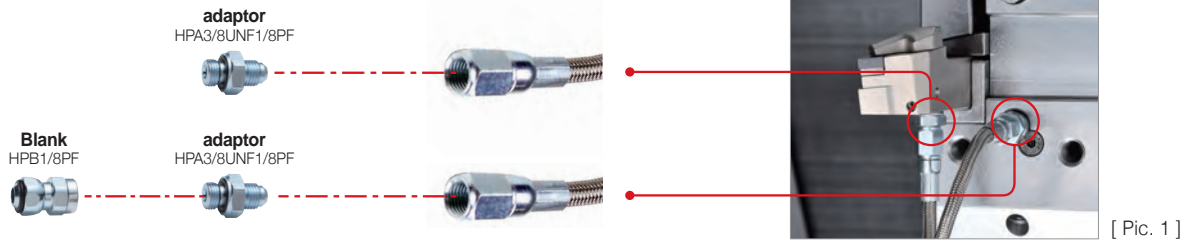

Straight to banjo (S-B)

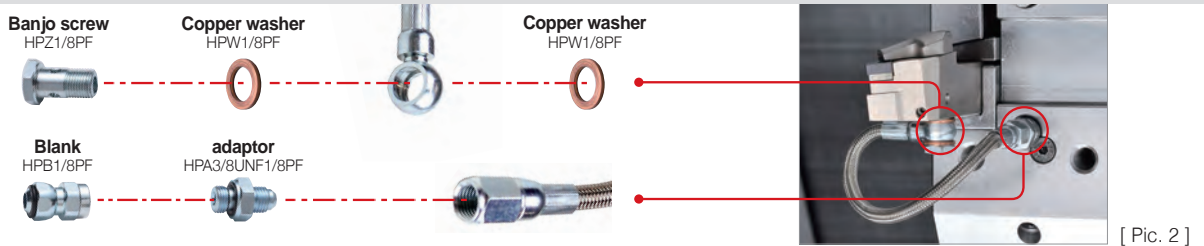

Banjo to banjo (B-B)

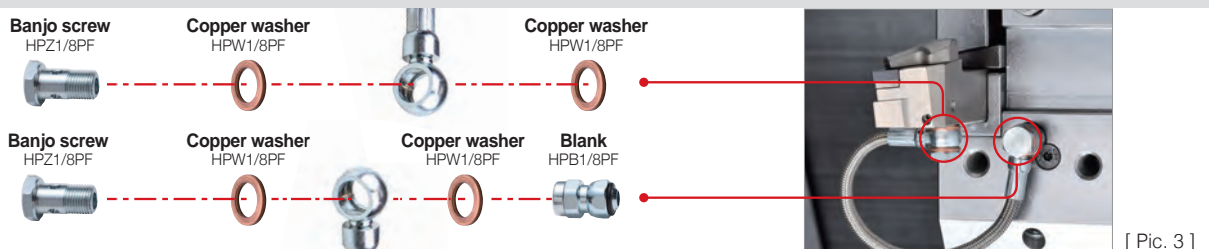



- ※ Blank including a fixed oil seal provides easy clamping
- ※ Banjo screws provide easy clamping and clamping a holder to the turning machine with various types of blanks









Components of KHP Coolant

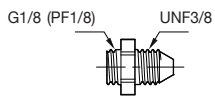

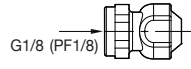
- The components of high pressure coolant are sold separately
- Various components are available according to different machining sites and uses machining with high pressure coolant

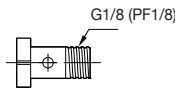
Designation	Shape	Hose length	High pressure hose	Blank	Adaptor	Banjo screw	Copper washer	Pic.		
HPH3/8UNF-200-SET		200 mm	1 EA	1 EA	2 EA	-	-	1		
HPH3/8UNF-250-SET		250 mm								
HPH3/8UNF1/8PF-200-SET		200 mm			1 EA	1 EA	1 EA	1 EA	3 EA	2
HPH3/8UNF1/8PF-250-SET		250 mm								
HPH1/8PF-200-SET		200 mm			-	2 EA	5 EA	3		
HPH1/8PF-250-SET		250 mm								

KHP Coolant Parts

Division	Designation	Shape
adaptor	HPA3/8UNF1/8PF	 
Blank	HPB1/8PF	 
Banjo screw	HPZ1/8PF	 
Copper washer	HPW1/8PF	 

KHP Coolant High pressure hose

High pressure hose shape		Length	S	B
Straight to straight (HPH3/8UNF)		200 mm	UNF3/8	-
		250 mm		
Straight to banjo (HPH3/8UNF1/8PF)		200 mm	UNF3/8	Internal Ø10
		250 mm		
Banjo to banjo (HPH1/8PF)		200 mm	-	Internall Ø10
		250 mm		

PCLNR/L

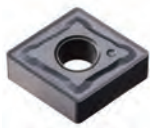

CN□□

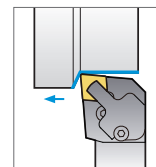
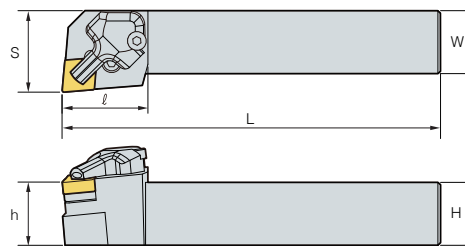
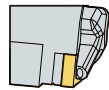

95°

• R type insert (mm)

Designation	H	W	L	S	h	l	Insert	Lever	Screw	Shim	Ship pin	Shim Pin Punch	Clamp	Clamping screw	Oil seal	Plug	Wrench
PCLNR/L 2525-M12-KHP	25	25	150	32	25	34	CN□□1204□□										
3232-P12-KHP	32	32	170	40	32	34											

➔ Applicable inserts B36~B42

PDJNR/L



DN□□

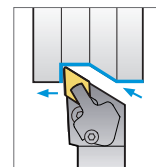
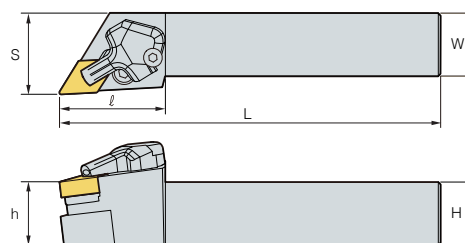
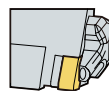

93°

• R type insert (mm)

Designation	H	W	L	S	h	l	Insert	Lever	Screw	Shim	Ship pin	Shim Pin Punch	Clamp	Clamping screw	Oil seal	Plug	Wrench										
PDJNR/L 2525-M11-KHP	25	25	150	32.25	25	42	DN□□1104□□																				
2525-M1504-KHP	25	25	150	32.25	25	42	DN□□1504□□											LV3AN	VHX0617N	SD32N	SP3	LSPS3	HPCR/L-H	MHB0415	HPO7S	KHA0404-NYLOCK	HW20L HW25L HW30L
2525-M1506-KHP	25	25	150	32.25	25	42	DN□□1506□□											LV4BN	VHX0821N	SD43N	SP4N	LSPS4	HPCR/L-H	MHB0415	HPO7S	KHA0404-NYLOCK	HW20L HW30L

➔ Applicable inserts B43~B48

PSSNR/L

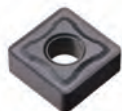

SN□□

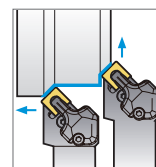
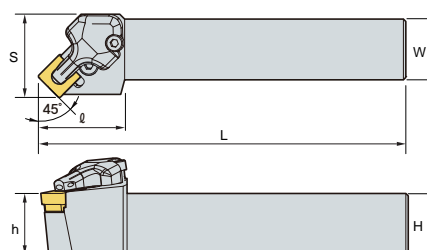
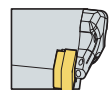

45°

• R type insert (mm)

Designation	H	W	L	S	h	l	Insert	Lever	Screw	Shim	Ship pin	Shim Pin Punch	Clamp	Clamping screw	Oil seal	Plug	Wrench
PSSNR/L 2525-M12-KHP	25	25	150	34.25	25	35.5	SN□□1204□□										
								LV4N	VHX0821	SS42N	SP4N	LSPS4	HPCR/L-3H	MHB0415	HPO7S	KHA0404-NYLOCK	HW20L HW30L

➔ Applicable inserts B50~B57



PWLNR/L



WN□□

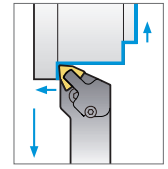
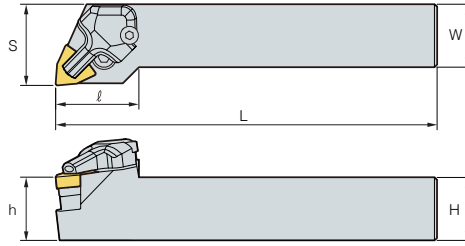
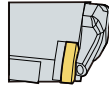

95°

• R type insert (mm)

Designation	H	W	L	S	h	ℓ	Insert	Lever	Screw	Shim	Ship pin	Shim Pin Punch	Clamp	Clamping screw	Oil seal	Plug	Wrench
PWLNR/L 2525-M08-KHP	25	25	150	32.25	25	33	WN□□0804□□										
3232-P08-KHP	32	32	170	39.25	32	33											

➔ Applicable inserts B68-B72

SRGCR/L



RCGT

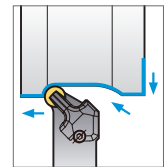
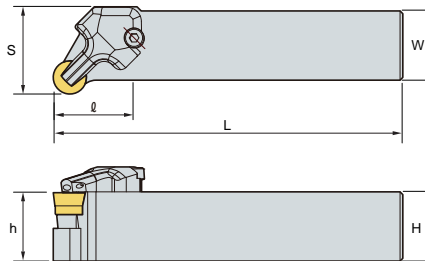

• R type insert (mm)

Designation	H	W	L	S	h	ℓ	Insert	Screw	Shim	Shim Screw	Clamp	Clamping screw	Oil seal	Wrench
SRGCR/L 2525-M12-KHP	25	25	150	31.5	25	-	RCGT1204M0							
								FTGA03512	SR12S	SHXN0509F	HPCR/L-3H	MHB0415	HPO7S	HW15P HW30L HW35L

➔ Applicable inserts B83, B105

SVJBR/L



VB□□

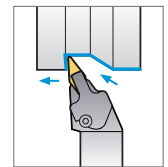
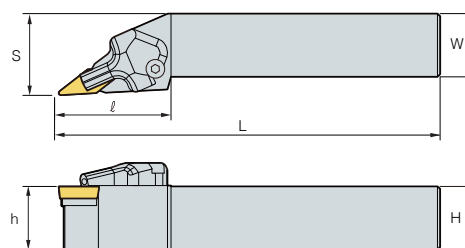

93°

• R type insert (mm)

Designation	H	W	L	S	h	ℓ	Insert	Screw	Shim	Shim Screw	Clamp	Clamping screw	Oil seal	Wrench
SVJBR/L 2525-M16-KHP	25	25	150	32.5	25	46.5	VB□□1604□□							
								FTGA03512	SV32S	SHXN0509F	HPCR/L-H	MHB0415	HPO7S	TW15P HW30L HW35L

➔ Applicable inserts B94-B96, B108